

THE NRCA ROOFING MANUAL
CONSTRUCTION DETAIL C-1

COPING

- 24 GA. STEEL
- 22 GA. STEEL CLEAT
- CONTINUOUS FRONT FACE CLEAT AND GASKETED BACK FACE FASTENER

**ANSI/SPRI ES-1
TESTED RESISTANCE**

OUTWARD	UPWARD
265 LBS./SQ. FT.	440 LBS./SQ. FT.

UL-4

10/30/15

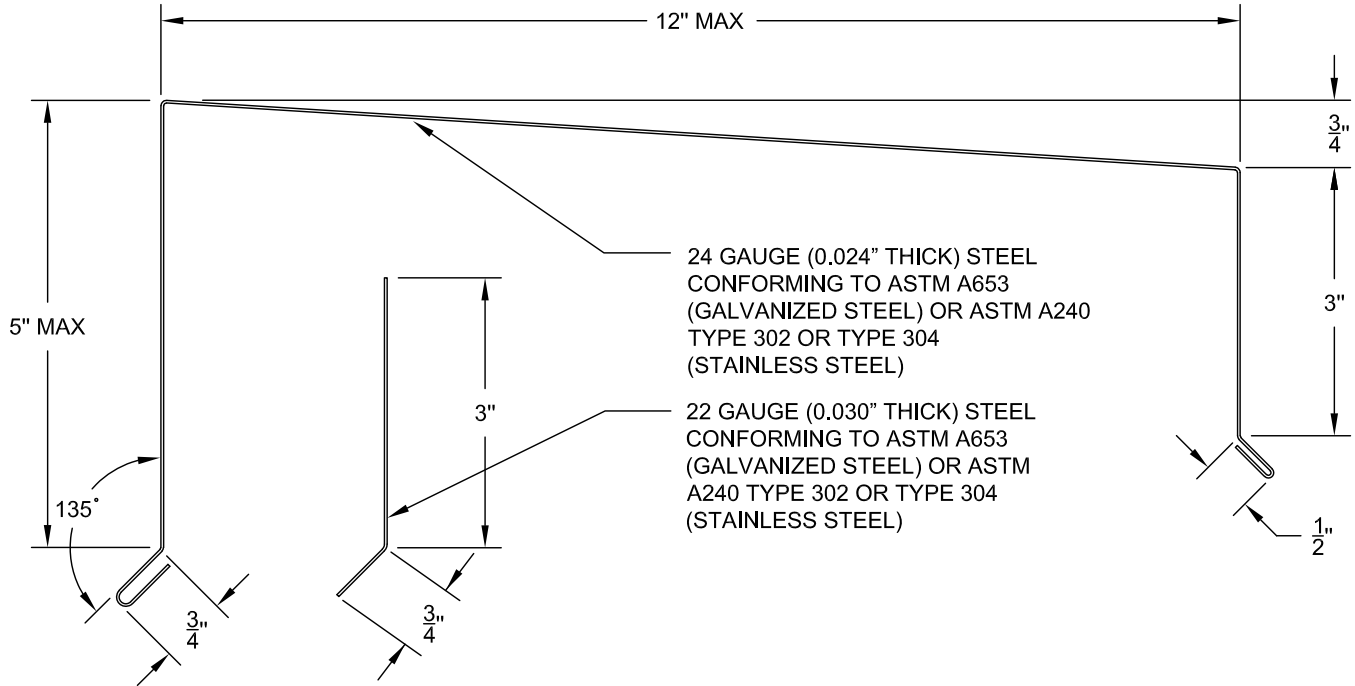

FABRICATION

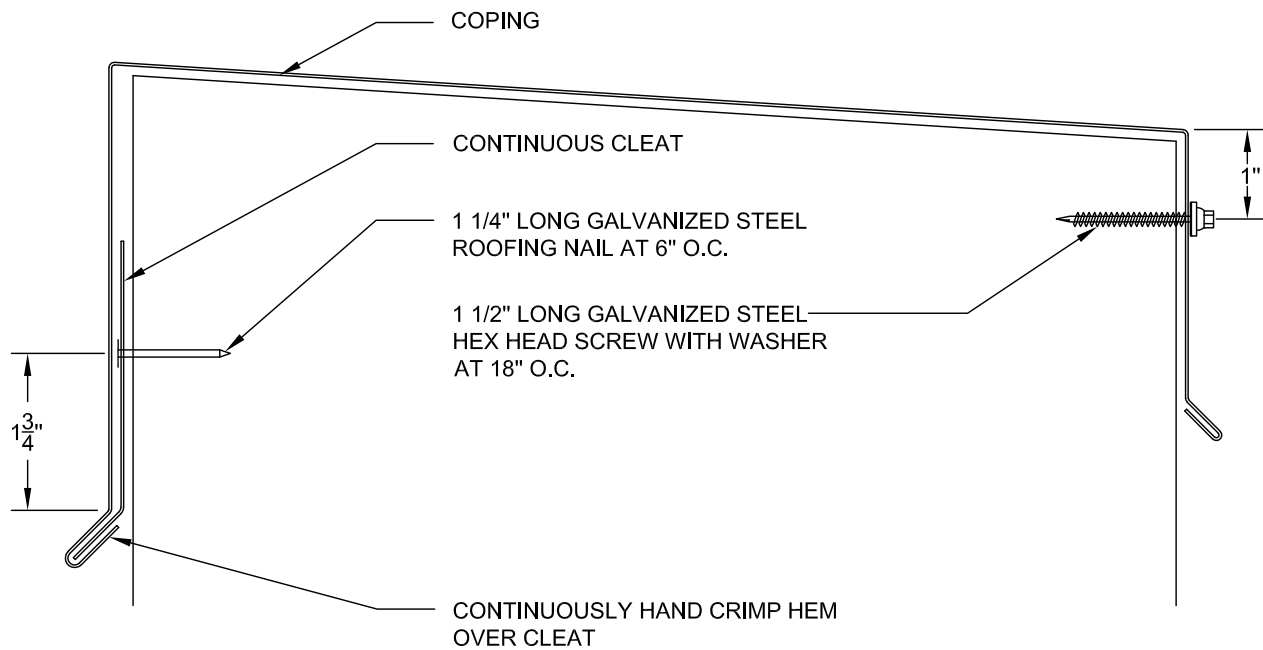

INSTALLATION



1515 Lake Wheeler Rd
Raleigh NC 27603
919-256-2270



NATIONAL ROOFING CONTRACTORS ASSOCIATION

THE NRCA ROOFING MANUAL CONSTRUCTION DETAIL C-1	COPING <ul style="list-style-type: none"> • 24 GA. STEEL • 22 GA. STEEL CLEAT • CONTINUOUS FRONT FACE CLEAT AND GASKETED BACK FACE FASTENER 	ANSI/EPRI ES-1 TESTED RESISTANCE		UL-4 10/30/15
		OUTWARD 265 LBS./SQ. FT.	UPWARD 440 LBS./SQ. FT.	



Peak Metal Products is an Authorized
Fabricator of ANSI/SPRI ES-1 UL
Approved Edge Metal Products

Always Good Work

Peak Metal is a Division of
Baker Roofing Company

